

UNLOADING OF 'L' TYPE RACKS WITH GLASS USING A FORKLIFT BY THE CUSTOMER.

1. The vehicle must be placed on a flat surface.
2. The air cushions of vehicle have to be empty (vehicle blocked) for unloading time.
3. The glass panes on the rack must be secured against falling. Unloading without protection is forbidden.
4. The glass panels on the rack must be secured with a minimum of two fastening elements, e.g. plastic tape, locking device, transport strap (steel straps must not be used), which exclude the risk of the glass tipping over even if the rack is slightly deflected from the vertical or horizontal.
5. Before unloading, it is advisable to check and, if necessary, correct the plastic straps securing the glass.
6. It is forbidden to transport racks of glass on uneven or sloping surfaces.
7. During unloading, avoid sudden movements and repeated shocks.
8. Keep away of unloading zone which is very dangerous. Is allowed stay out of transport path.
9. Be careful to avoid mechanical damages.
10. Forks should be inserted from the rear side of the rack. Insert the forks of the trolley into the rack as far as possible. The mast should be tilted "backwards".

10.1. NOTE EXCEPTIONS!

10.1.1. Rack types 30.061A5 and 30.01B.032B (Figs. 1 and 2) are suitable for fork-lift truck transport from the shorter side - they have additional guides that ensure the forks are symmetrical with respect to the rack. This type of transport is only permitted with a forklift truck and an electric pallet truck with a minimum fork spacing of 500 mm. This type of racking has blue top beams for easy identification.

PILKINGTON IGP Sp. z o.o. based in Sandomierz

27-600 Sandomierz, 24 Portowa Street, tel. 48 15 8323041-49 or 48 15 8326100 fax 48 15 832 62 89
REGON 006911139 NIP (Tax Identity Number) 123-00-06-857 District Court in Kielce, X Commercial Division of the National Court
Register under KRS number 0000012897 Individual BDO Number 000003517

Share Capital: 506 500 PLN

Management Board: President – Krzysztof Granicki

www.pilkington.pl

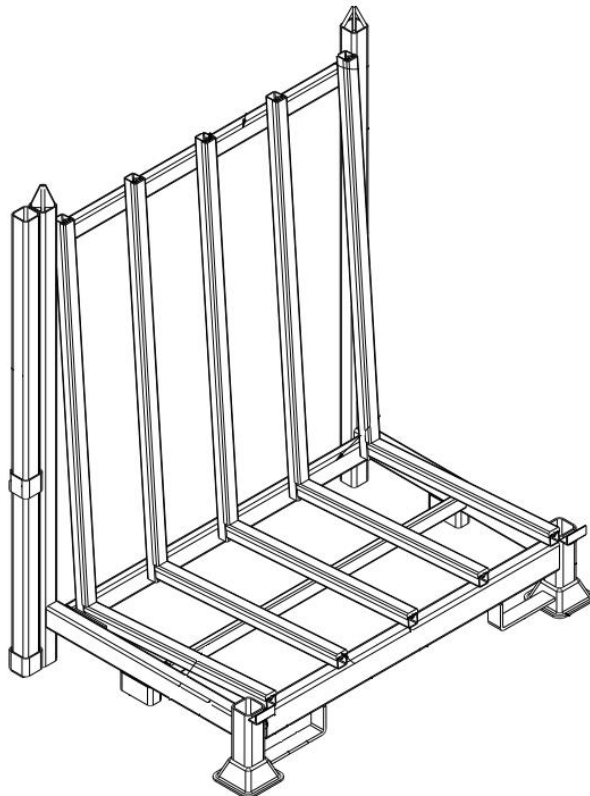

Fig. 1 (Rack type 30.061A5) - Rack model with lateral gripping capability

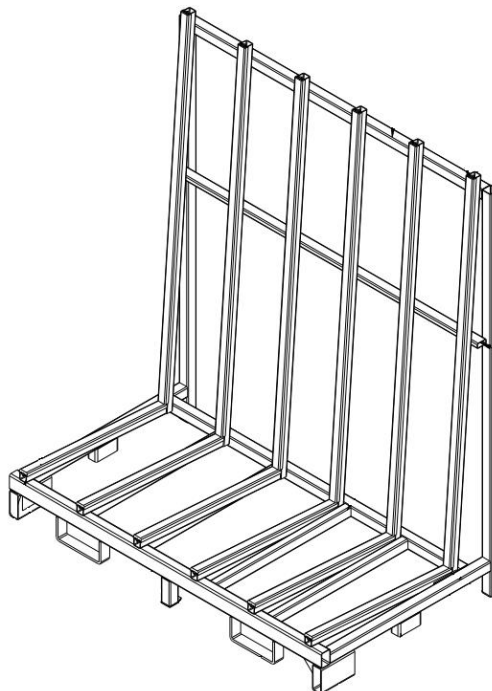

Fig. 2. (Rack type 30.01B.032B) - Rack model with side gripping capability

11. The rack with the packed glass should be lifted slightly to check that it is not excessively tilted and then transported carefully.

11.1. Permissible tilting of a **single** rack (Figure 3):

11.1.1. from vertical to 4%,

11.1.2. a horizontal base slope of up to 5%.

11.2. Permissible tilt of **two** stacked racks (Figure 4):

11.2.1. from vertical to 2%,

11.2.2. a horizontal base slope of up to 3.2%.

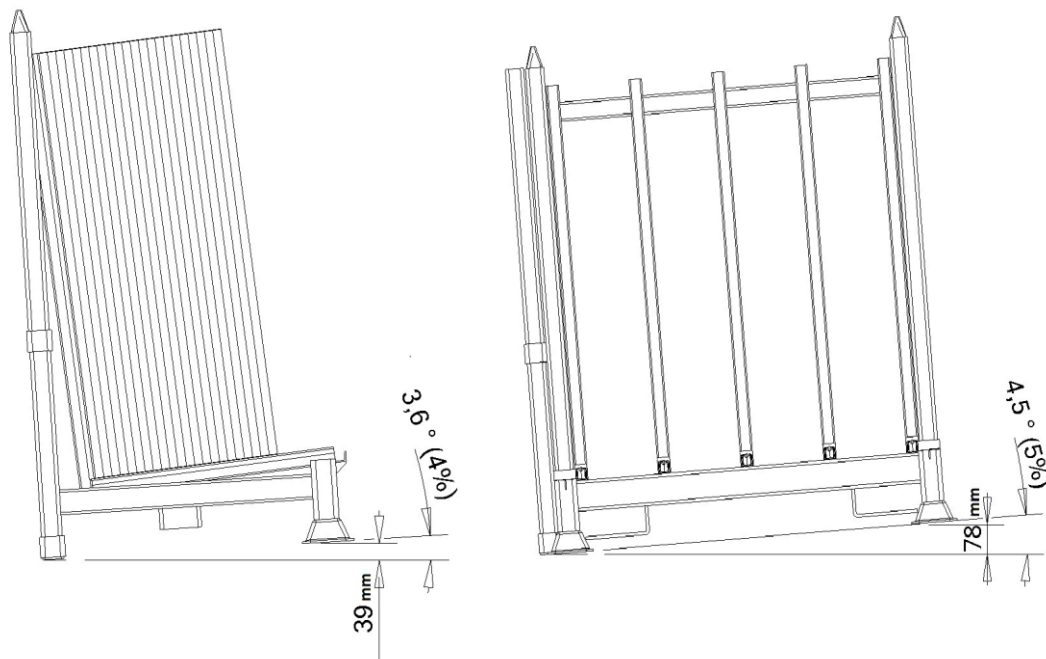

Fig. 3 - Permissible vertical and horizontal deflection of a single stand during transport.

PILKINGTON IGP Sp. z o.o. based in Sandomierz

27-600 Sandomierz, 24 Portowa Street, tel. 48 15 8323041-49 or 48 15 8326100 fax 48 15 832 62 89
 REGON 006911139 NIP (Tax Identity Number) 123-00-06-857 District Court in Kielce, X Commercial Division of the National Court
 Register under KRS number 0000012897 Individual BDO Number 000003517

Share Capital: 506 500 PLN

Management Board: President – Krzysztof Granicki

www.pilkington.pl

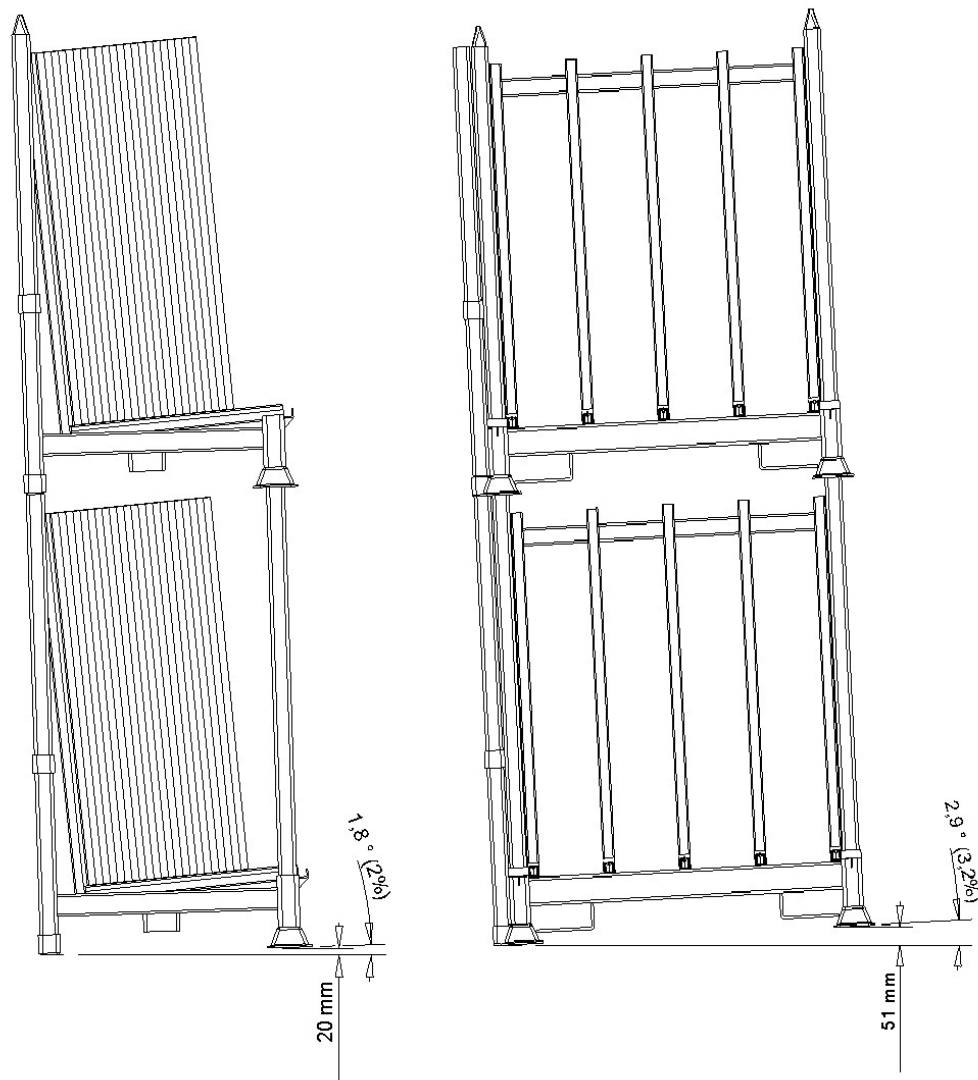

Fig. 4 - Permissible vertical and horizontal deviation of two stacked racks during transport.

12. A maximum of two racks stacked on top of each other may be transported. In the case of racks with loads of different weights, there should be a heavier rack at the bottom and a lighter one at the top.
13. The forks of the trolley should be at a height of 30 cm from the ground during transport.
14. Make sure the route is clear before unloading.
15. Watch the crossing route, do not drive "blindly" !
16. Adapt your speed to the condition of the road surface in the working area and to the load being carried.

PILKINGTON IGP Sp. z o.o. based in Sandomierz

27-600 Sandomierz, 24 Portowa Street, tel. 48 15 8323041-49 or 48 15 8326100 fax 48 15 832 62 89
REGON 006911139 NIP (Tax Identity Number) 123-00-06-857 District Court in Kielce, X Commercial Division of the National Court
Register under KRS number 0000012897 Individual BDO Number 000003517

Share Capital: 506 500 PLN

Management Board: President – Krzysztof Granicki

www.pilkington.pl

17. Do not make any sudden manoeuvres with forklifts when transporting a load (accelerating, braking, turning).
18. It is forbidden to move loaded racks by sliding, pushing or pulling.
19. Workers involved in unloading racks of glass from a truck should work together - see each other and be able to communicate using a known signalling code.
20. Observe the other recommendations in the forklift operating manual.
21. This manual applies to racks with the following nameplate designations: initial rack numbers 30.061A5, 30.03..., 30.01B.03... to 30.01B.09.... and 30.01B.032B

Approved:

Director of Operations Pilkington IGP Sp. z o. o. Dariusz Kowalczyk

Sandomierz, 02-10-2023

PILKINGTON IGP Sp. z o.o. based in Sandomierz

27-600 Sandomierz, 24 Portowa Street, tel. 48 15 8323041-49 or 48 15 8326100 fax 48 15 832 62 89
REGON 006911139 NIP (Tax Identity Number) 123-00-06-857 District Court in Kielce, X Commercial Division of the National Court
Register under KRS number 0000012897 Individual BDO Number 000003517

Share Capital: 506 500 PLN

Management Board: President – Krzysztof Granicki

www.pilkington.pl